



**ARRIS**

# Professional Services

**Full Service Experience. Delivered.**

Convergence Enabled.

# Network Analysis – Engineering – Implementation – Management – Maintenance

For over 50 years, ARRIS has provided the Broadband, On Demand and OSS products and services needed to successfully build and maintain multi-service communications networks around the world. This expertise represents a distinct set of advantages for our customers. Broadband service providers worldwide are racing to cost effectively deliver quad play broadband services over cable, wireless, satellite, and other broadband communications networks, and they get a head start by choosing ARRIS solutions.

Choosing an experienced partner to help deploy new technologies ensures that a broadband service provider's offering is brought to market quickly and without excess cost or risk. ARRIS Professional Services expertise in program management and solutions implementation, training, and global technical support assists customers in rolling out next-generation services to ensure an optimal deployment lifecycle.

## ARRIS Professional Services include:

- *Planning, Business Analysis & Assessment Services*
- *Design & Engineering Services*
- *Program Management & Implementation Services*
- *Maintenance & Management Services*



## PLANNING, BUSINESS ANALYSIS & ASSESSMENT SERVICES

Understanding the needs of the business as a whole, its strategic direction, and identifying initiatives to meet those strategic goals can be a daunting task. With continued advancements in technology and business tools, maximizing investments to achieve strategic goals can be an even greater challenge. ARRIS Professional Services has the knowledge and discipline to help identify requirements that enable organizations achieve long range financial, technical and strategic milestones. We use techniques to ensure that all stakeholders have a shared understanding of the requirements and how they will be implemented. ARRIS offers a comprehensive sustaining program, which covers capacity and traffic planning. This ensures optimal performance of the technologies and solutions without overspending on capital investment and maximizing on the ROI. New technology, coupled with the ARRIS world class Assurance platforms, provide proven, hardened tools to capitalize on network investments and provide a detailed deployment plan for new services while increasing competitive advantages for rapid execution.

### Planning, Business Analysis & Assessment Services

- *Business consulting*
- *Process evaluation*
- *Audit of network readiness*
- *Network and financial modeling*
- *Network OSS and application planning*
- *Operation analysis and optimization*

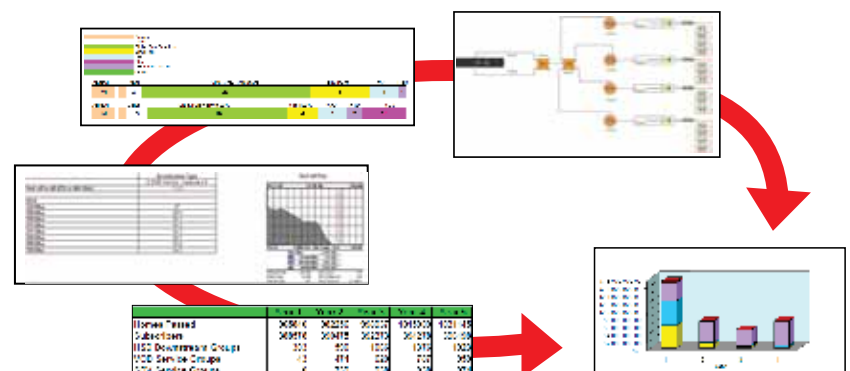

## DESIGN & ENGINEERING SERVICES

All projects have their own unique considerations: network constraints, performance criteria and technical needs, among other dynamics. Together they define a project's engineering and design challenges. With this perspective, ARRIS applies its global technical experience and resources to arrive at the precise solution for our clients, to meet their unique needs and challenges. Solid engineering and design capabilities are one of our core competencies, developed over more than 50 years of completing some of the most complex technology projects anywhere. This translates into highly optimized, reliable and quality engineering design standards. The ARRIS team's detailed knowledge of both technological and physical infrastructure allows us to provide services in network design, outside plant design, and business service solutions engineering – all optimized for seamless deployment of solutions into the field for rapid revenue generation.

### ***Design & Engineering Services***

- *Detailed engineering design (Voice, Video, Data & Wireless)*
- *Network design and drafting (OSP, FTTH, and HFC)*
- *Field survey and documentation services*
- *Facility design*
- *Network optimization engineering*

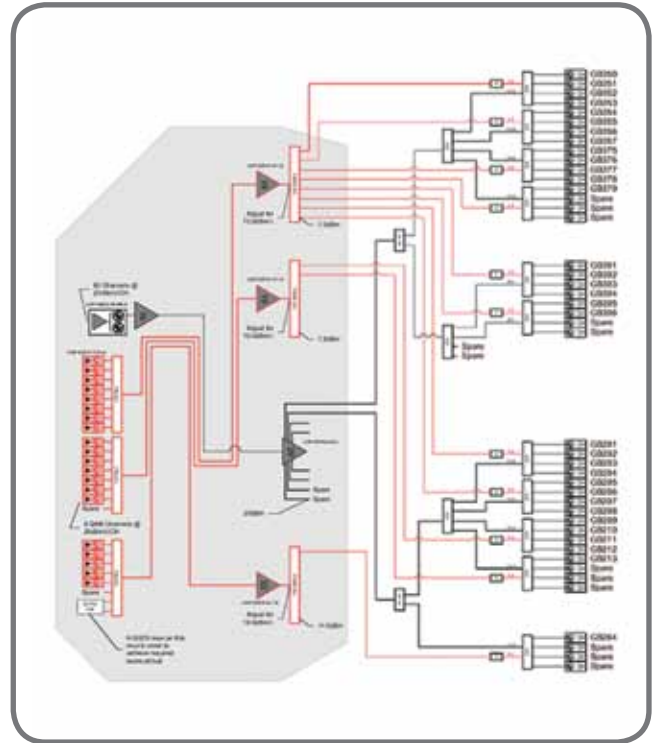

## PROGRAM MANAGEMENT & IMPLEMENTATION SERVICES

The ARRIS Program Management and Implementation Group boasts a veteran team of technical professionals with extensive real-world, hands on experience. Our expertise spans the full range of skills needed to implement Video, Voice, Data, Wireless or OSS applications. Our solutions fully meet the needs of broadband service providers while providing carrier class reliability to end-users. We are skilled in every phase of managing business deployments, such as installation, testing, commissioning, flow-through provisioning and maintenance services. We work with broadband service providers to design, install and deploy a full portfolio of integrated solutions. We guide your entire project—from the initial needs assessment and solutions design through development, trial deployments, full rollouts, and life-cycle support. To ensure maximum scalability and an easy migration path for the solution, the ARRIS Program Management team works in close partnership with our product management, core development, and technical support teams to create designs that optimize the use of existing and next-generation technologies. In addition, ARRIS has strong alliances with major technology companies and systems integrators which provide seamless access to best practices from other industry leaders to provide you a complete turnkey solution.

- *Program and project management*
- *Deployments and installation*
- *Solution verification testing*
- *Systems integration*
- *Process deployments*
- *Quality Assurance & Quality Control auditing*



## MAINTENANCE AND MANAGEMENT SERVICES

The increasing complexity of networks poses an ever greater challenge to maintaining and operating a carrier class network. Transitioning and training personnel on newly deployed solutions are critical in its maintenance. ARRIS can provide long or short term knowledge transfer assistance along with comprehensive training to transition your staff to new responsibilities. In addition to our world class technical support, we also offer proactive monitoring to allow for maximum uptime of your network. Combining technical expertise with sophisticated monitoring tools, ARRIS can monitor your network elements, not only at the core but including application servers and devices distributed throughout the network. If an event or failure occurs, we quickly react to repair or replace system components or functions, thereby maintaining high network reliability.

### ***Maintenance & Management Services***

- *Long and short term staff augmentation*
- *Network management and monitoring*
- *Customized training and technical support*
- *Continuous improvements*



## THE BOTTOM LINE

ARRIS Professional Services provides exceptional quality network design, integration, deployment, technical consulting, and outsourcing services to network operators. For temporary or long-term deployment and dependable technical assistance, the experienced and highly skilled engineers and technicians of ARRIS are only a phone call away.