



C-COR® Flex Max901e

1 GHz Trunk Amplifiers



- 1 GHz technology
- Can be preconfigured for 870 MHz operation for drop-in spare application
- -20 dB and -25 dB internal or external testpoints
- Expanded ALC pilot selection to match existing system designs
- Accepts all C-COR legacy 750 and 870 MHz equalizer and cable simulator plug-in accessories
- Supports major EMS protocols

The ARRIS C-COR Flex Max901e 1 GHz Trunk Amplifiers are the new industry standard for RF distribution products. 1 GHz will enable broadband service providers to increase forward capacity for HDTV over previous program offerings, typically allowing a 40% increase over current HDTV channels in a lineup.

The high forward gain and output configurations provided by Flex Max901e Trunk Amplifiers are designed to overcome the higher insertion losses of coaxial cable and passives, and to ensure cost-effective new designs and drop-in upgrades of existing 750 and 870 MHz systems.

Flex Max901e Trunk Amplifiers are available as complete units for deploying new system builds, and, as drop-in RF modules for a 1 GHz upgrade of C-COR legacy 750 MHz and 870 MHz FlexNet trunk amplifiers. In addition, the trunk amplifiers can be preconfigured for deployment as spares in 750/870 MHz systems. Operating specifications, such as gain and tilt, are maintained at 750 MHz and 870 MHz, with extended gain and tilt out to 1002 MHz. These unique design considerations enable reuse of legacy amplifier housings and existing spacing, which in turn eliminates the cost of resplicing, making the Flex Max901e drop-in RF module an economical choice for system upgrades up to 1 GHz.

Features

- Operational specifications designed to enable legacy system upgrades without the need for resplicing existing amplifier housings
- Factory aligned to 1 GHz specifications, but can be deployed into 750/870 MHz applications with field accessible plug-ins

- Plug-in diplex filters for future frequency split upgrades (bench upgrade only)
- Accessory insertion guides ease installation
- Optional 90° access ports for cost effectiveness in underground installations

Functional Block Diagram

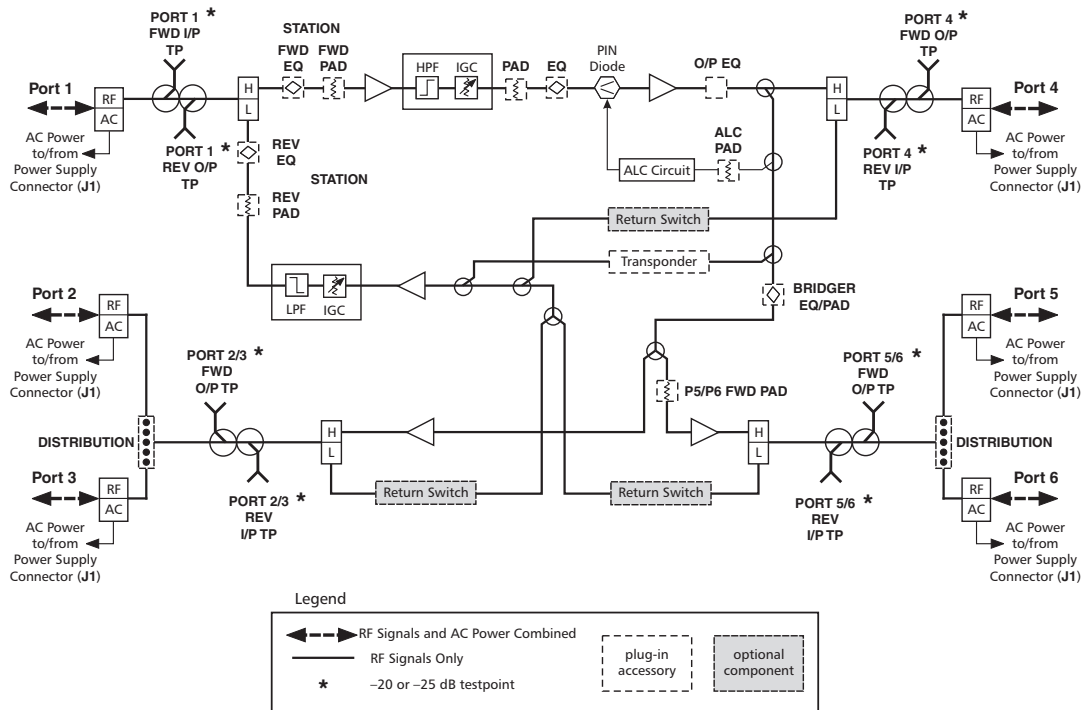

Flex Max901e Trunk Amplifier

Application

The Flex Max901e Trunk is a three active output station that provides one trunk level output and two distribution level outputs. The two active distribution or bridger ports can be configured in the field to provide four outputs. Flex Max901e Trunks provide a high performance trunk level output to "express" to other Trunks in the cascade for maximum distortion performance.

The Flex Max901e Bridger is used at the end of the express line. The Flex Max901e Bridger provides two high-level distribution outputs, which can also be configured in the field to provide four outputs. These distribution ports can be independently configured for specific applications.

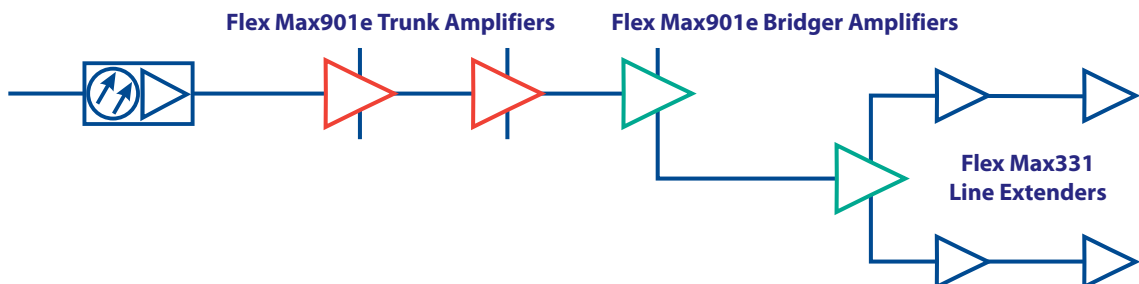

Flex Max901e Trunk Amplifier Sample Specifications

| | Trunk | Forward 2-Output Bridger | Return Trunk and Bridger |
|---|------------------------|-----------------------------|-----------------------------|
| General | | | |
| Passband, MHz | | 54–1002 | 5–42 |
| Housing, MHz | | 1002 | — |
| AC Current Passing, A—Ports 1, 3, 4, 6 | | 15 | 15 |
| AC Current Passing, A—Ports 2, 5 | | 13 | 13 |
| Typical Operating Conditions | | | |
| Operational Gain dB (–0, +0.5) (Notes 1 and 2) | 33 | 43 | 18 |
| Channels, Number of NTSC (Note 3) | 79 | 79 | 6 |
| Operating Levels (recommended) | | | |
| Frequency, MHz | 1002/870/750/550/54 | 1002/870/750/550/54 | 42/5 |
| Input, dBmV, min. (Note 4) | 9.0/8.4/8.4/7.6/9.2 | 9.0/8.4/8.4/7.6/9.2 | 17/17 |
| Output, dBmV (Notes 5 and 6) | 42/40.5/39.5/37/32 | 52/49.5/47.5/44/35 | 35/35 |
| Performance Specifications @ Recommended Levels | | | |
| Temperature Range: –40 to 60°C | | | |
| Carrier-to-Interference Ratio, dB (Note 7) | | | |
| Composite Triple Beat | 84 | 75 | 80 |
| Second Order Beat (F1 ± F2) | — | — | — |
| Cross Modulation (per NCTA std.) (Note 8) | 76 | 67 | 74 |
| Third Order Beat (F1 ± F2 ± F3) | — | — | — |
| Composite 2IM | 79 | 73 | 82 |
| Comp. Intermodulation Noise (CIN) (Note 9) | 80 | 66 | — |
| Comp. Intermodulation Noise (CIN) (Note 10) | 86 | 72 | — |
| Noise, 4MHz, 75 Ohms (Note 2) | 59/59.4/59.4/57.6/57.2 | 59/59.4/59.4/57.6/57.2 | 62 |
| Noise Figure, dB (without EQ) (Note 11) | 8/7/7/8/10 | 8/7/7/8/10 | 14 |
| Full Gain, dB (without EQ and ALC) | 38 | 48 | 19 |
| Factory Alignment (with ALC Reserve, without EQ) | | | |
| Cable Loss, dB @ 1002MHz | 13 | 13 | — |
| Linear Equalization, dB (Note 12) | — | 8 | — |
| Flat Loss, dB (Note 13) | 21 | 31 | 19 |
| Gain Slope, dB | –0.5 to 1.0 | –1.0 to 1.0 | — |
| Flatness (@ Gain Slope), ±dB (Notes 14 and 15) | 0.75 | 1.0 | 0.5 |
| Return Loss, dB min., all entry ports | 16 | 16 | 16 |
| Powering Requirements, max./typ. (Note 16) | | | With Active Return |
| AC Voltage, 60Hz | | | @ 90V @ 60V |
| AC Power, Watts | | | 53.5/49 53/48 |
| AC Current, mA | | | 735/700 970/880 |
| DC Current, mA @ 24V ± 0.5V | | | 1955/1775 1955/1775 |
| Level Control | | | |
| Range, dB @ 1002MHz | | +4.0/–5.0dB | — |
| Accuracy (–40 to 60°C) | | ±0.5dB | — |
| Pilot Level Range (Note 17) | | +5/–3dB | — |
| Pilot Frequency Band (recommended) (Note 18) | | 499.25MHz (single channel,) | — |

Specification Document Number 1502212 Rev C

Notes:

- Spacing is at highest frequency with SEQ-1G-xx installed. Return spacing includes losses due to housing, diplex filters, and MEQ-42-xx.
- Specifications are based on the the amplifier configured (with two SPB-0) as a 2-output bridger with distribution outputs on ports 3 and 6. When using distribution plug-ins (SS-1000-2, SDC-1000-8, or SS-1000-12), levels should be derated accordingly, based on the accessory specification.
- NTSC video channels occupying the appropriate frequency spectrum per specified number of channels.
- Recommended minimum forward input level at 1002MHz including loss due to equalizer.
- Recommended maximum return output level at 42MHz including loss due to equalizer.
- Bridger output: at specified operational tilt the maximum output level for 870MHz or 1GHz loading is 56.5dBmV @ HF.
- Distortion performance is derated accordingly to account for the influence of the digitally compressed channels 6dB below equivalent video channels.
- Cross modulation specification indicates typical cascade performance.
- System operating with digitally compressed channels or equivalent broadband noise from 550 to 1002MHz at levels 6dB below equivalent video channels will experience a composite distortion (CIN) appearing as noise in the 54 to 550MHz frequency spectrum.
- Systems operating with digitally compressed channels or equivalent broadband noise from 550-870 MHz at levels 6 dB below equivalent video channels will experience a composite distortion (CIN) appearing as noise in the 54-550 MHz frequency spectrum.
- Noise figure and C/N specifications are typical within the specified passband.
- Difference in linear loss between 54MHz and 1002MHz.
- Total flat loss at 1002MHz which includes insertion loss of linear EQ.
- Forward bridger port gain and flatness is 11 ± 1.0dB as referenced to the trunk port and is measured with an additional 10dB of cable loss at 1002MHz. Return bridger port gain and flatness is 0 ± 0.5dB as referenced to the trunk port.
- Reverse bridger port gain and flatness is 0 ± 0.5dB as referenced to trunk port.
- Powering requirements indicated are with the Model HEP5790-2.3 power supply 122027-05. See 333995-17 for additional information. For 60VAC Powering:

C-COR® Flex Max901e 1 GHz Trunk Amplifier

AC Power consumption in Watts divided by a factor of 43 = Amps required. For 90VAC Powering: For £ 67VAC, 1.03 x (AC Power consumption in watts divided by voltage) = Amps required. For 67 - 90VAC, AC Power consumption in watts divided by 65 = Amps required.

17. ALC pilot level range is based on a nominal pilot level of 37 dBmV for pilot frequencies ≤ 499.25 MHz or 32 dBmV for pilot frequencies > 499.25 MHz. ARRIS recommends that if the pilot level, from a design standpoint, is more than +2/-1 dBmV from nominal, the ALC PAD should be changed to optimize the ALC pilot level range. This should alleviate any possible ALC setup and/or operation issues due to typical system level variations caused by system components flatness characteristics. See the FM901e equipment manual (P/N 1502154) for correct selection of ALC PAD value to insure proper ALC setup and operation.
18. For ALC pilot frequencies of £ 499.25 MHz, the ALC pilot filter is a single channel device. This means that the adjacent channels will have no effect on the RF power level that the RF detector is measuring. For ALC pilot frequencies > 499.25 MHz, the ALC pilot filter is not a single channel device. This means that the adjacent QAM channels will have an effect on the RF power level that the RF detector is measuring. ARRIS recommends that the adjacent QAM channels be present on the system before the ALC system of the amplifier station is balanced. This will avoid station re-balance in the future when those QAM channels would be added to the system.
19. Specifications are typical for Flex Max901e Trunks. Contact your ARRIS sales professional for Flex Max901e Bridger specifications.
20. Specifications for 870MHz trunk configurations are available on request (*Specification document number 1502211*).

Specifications subject to change without notice

Ordering Information

| | 1 | 2 | 3 | 4 | | 5 | 6 | 7 | 8 | 9 | 10 | 11 | 12 |
|--|----------|----------|----------|----------|----------|----------|----------|----------|----------|----------|----------|----------|----------|
| F | M | T | E | X | X | X | - | X | X | X | X | X | N |
| 1 Series | | | | | | | | | | | | | |
| E Flex Max901e series | | | | | | | | | | | | | a |
| a) 15 A current passing capability. | | | | | | | | | | | | | |
| 2 Bandwidth | | | | | | | | | | | | | |
| D 1002/870/750MHz | | | | | | | | | | | | | a |
| G 1002MHz | | | | | | | | | | | | | b |
| a) Preconfigured using equal trunk and bridger output tilts for deployment at 1002/870/750MHz. Must choose "5" in #3 block, Spacing . | | | | | | | | | | | | | |
| b) Must choose "8" in #3 block, Spacing . | | | | | | | | | | | | | |
| 3 Spacing | | | | | | | | | | | | | |
| 5 32dB | | | | | | | | | | | | | a |
| 8 33dB | | | | | | | | | | | | | b |
| a) 18 dB factory equalization. Must choose "D" in #2 block, Bandwidth . | | | | | | | | | | | | | |
| b) 13 dB factory equalization. Must choose "G" in #2 block, Bandwidth . | | | | | | | | | | | | | |
| 4 Frequency Split | | | | | | | | | | | | | |
| J 42/54MHz | | | | | | | | | | | | | |
| N 65/85MHz | | | | | | | | | | | | | |
| Q 55/70MHz | | | | | | | | | | | | | |
| 5-6 Level Control | | | | | | | | | | | | | |
| K0 427.25MHz NTSC TV | | | | | | | | | | | | | |
| KB 439.25MHz NTSC TV | | | | | | | | | | | | | |
| KC 451.25MHz NTSC TV | | | | | | | | | | | | | |
| KL 423.25MHz NTSC TV | | | | | | | | | | | | | |
| KN 471.25MHz NTSC TV | | | | | | | | | | | | | |
| L0 499.25MHz NTSC TV | | | | | | | | | | | | | |
| L4 495.25MHz NTSC TV | | | | | | | | | | | | | |
| MB 645.00MHz QAM | | | | | | | | | | | | | |
| RM 711.00MHz QAM | | | | | | | | | | | | | |
| SD 609.00MHz QAM | | | | | | | | | | | | | |
| 7 Return | | | | | | | | | | | | | |
| 3 14.5dB active gain | | | | | | | | | | | | | a |
| 6 18dB active gain | | | | | | | | | | | | | b |
| 7 18dB active gain with return switches | | | | | | | | | | | | | c |
| a) Select "D" in #2 block, Bandwidth . | | | | | | | | | | | | | |
| b) Select "7" if future element management transponder is desired. | | | | | | | | | | | | | |
| c) Operation of return switches requires a transponder. | | | | | | | | | | | | | |
| 8 Output Configuration | | | | | | | | | | | | | |
| F Trunk with two bridger outputs—user configurable to 4 outputs with -25dB External testpoints | | | | | | | | | | | | | a, e |
| H Trunk with two bridger outputs—user configurable to 4 outputs with -20dB Internal testpoints | | | | | | | | | | | | | b, e |
| P Trunk with two bridger outputs—user configurable to 4 outputs with -20dB External testpoints | | | | | | | | | | | | | c, e |
| S Trunk with two bridger outputs—user configurable to 4 outputs with -25dB Internal testpoints | | | | | | | | | | | | | d, e |
| a) Select "A"; "F"; or "L" in #10 block, Housing . | | | | | | | | | | | | | |
| b) Select "A"; "C"; or "K" in #10 block, Housing . | | | | | | | | | | | | | |
| c) Select "A"; "F"; or "L" in #10 block, Housing . | | | | | | | | | | | | | |
| d) Select "A"; "C"; or "K" in #10 block, Housing . | | | | | | | | | | | | | |
| e) Plug-in splitters and directional couplers must be ordered separately. | | | | | | | | | | | | | |
| 9 Powering | | | | | | | | | | | | | |
| 1 None | | | | | | | | | | | | | a |
| 6 2.3A, 90V, 50/60Hz, H.E. transformerless | | | | | | | | | | | | | b |
| a) Select "A" in #10 block, Housing . Required when ordering RF module only. | | | | | | | | | | | | | |
| b) 40-90 V operating range; includes detachable cable. | | | | | | | | | | | | | |
| 10 Housing | | | | | | | | | | | | | |
| A None | | | | | | | | | | | | | a |
| C 6-port Flex Max, 1 GHz, Internal testpoints | | | | | | | | | | | | | b |
| F 6-port Flex Max, 1 GHz, External testpoints | | | | | | | | | | | | | c |
| K 6-port Flex Max, 1 GHz, four 90° access ports, Internal testpoints | | | | | | | | | | | | | b |
| L 6-port Flex Max, 1 GHz, four 90° access ports, External testpoints | | | | | | | | | | | | | c |
| a) Select "1" in #11 block, Housing Finish . Required when ordering RF module only. | | | | | | | | | | | | | |
| b) Select "H" or "S" in #8 block, Output Configuration . | | | | | | | | | | | | | |
| c) Select "F" or "P" in #8 block, Output Configuration . Forward external testpoints only. | | | | | | | | | | | | | |
| 11 Housing Finish | | | | | | | | | | | | | |
| 1 Standard (or N/A) | | | | | | | | | | | | | a |
| 4 Corrosion protected | | | | | | | | | | | | | |
| a) Required when ordering RF module only. | | | | | | | | | | | | | |
| 12 Element Management | | | | | | | | | | | | | |
| N EMS capable | | | | | | | | | | | | | a, b |
| a) Transponder sold separately: AM protocol (P/N 810-0354-01A) HMS protocol (P/N 810-0354-01H) | | | | | | | | | | | | | |
| b) Must order mounting bracket kit (P/N 1501024) | | | | | | | | | | | | | |



The capabilities, system requirements and/or compatibility with third-party products described herein are subject to change without notice. ARRIS, the ARRIS logo, C3™, C4™, CableEdge™, Cadant™, C-COR™, CHP Max™, Cornerstone™, CXM™, D5™, Digicon™, Flex Max™, Keystone™, MONARCH™, n5™, nABLE™, NSM™, nVision™, PLEXIS™, Regal™, ServAssure™, TeleWire Supply™, Touchstone™, VoiceAssure™, and WorkAssure™ are all trademarks of ARRIS Group, Inc. Other trademarks and trade names may be used in this document to refer to either the entities claiming the marks and the names of their products. ARRIS disclaims proprietary interest in the marks and names of others. © Copyright 2008 ARRIS Group, Inc. All rights reserved. Reproduction in any manner whatsoever without the express written permission of ARRIS Group, Inc. is strictly forbidden. For more information, contact ARRIS.

FM901eT-D-0208



www.arrisi.com