



## C-COR® CHP Max5000

GFX(V)-DF

### 1 GHz Forward Path Transmitters

#### Front Fiber

#### Converged Headend Platform

- 1GHz technology
- Unlock HDTV bandwidth
- Revolutionary variable optical output
- Higher fixed optical outputs available
- Dual high isolation input
- Low profile footprint allows 200 transmitters in a standard rack
- Universal local or remote management through Craft interface and SNMP with HMS



The CHP Max5000 Advanced 1 GHz Transmitter Suite will enable broadband service providers to increase forward capacity for HDTV over previous program offerings, thereby allowing typically 40% increase over current HDTV channels in a lineup. CHP Max5000 1 GHz transmitters are front fiber, dual-input, variable and fixed output, hot-swappable transmitters with integrated management through the local Craft GUI and remote management via SNMP HMS-compliant interface for external connection to an element manager.

The ARRIS revolutionary variable optical output power range enables operators to reduce spare inventory up to 60 percent, reduce the need for optical attenuators, and account for unexpected link loss during system implementation. These benefits translate into significant CapEx and OpEx savings, and provide maximum flexibility for deploying advanced interactive services. The 1 GHz Transmitter's dual-input capability provides isolation that is much superior to alternative offerings, enabling simultaneous advanced service deployment of video and telephony without cross-talk impairments. In addition, integral high isolation eliminates having to add external devices to achieve similar performance, thereby lowering CapEx even further and reducing system complexity.

Fixed output transmitters are also available with the same performance level as the variable output transmitters. Up to 10 CHP Max5000 transmitters can reside in the 2RU CHP Max5000 chassis, with RF input and optical bulkhead connector access on the rear panel. Thus, a standard 40RU rack holds up to 200 CHP Max5000 transmitters, providing exceptional space efficiency and reducing operational costs.

## Features

- Variable optical output power range for spare inventory reduction and flexibility to account for unexpected link loss during system implementation
- Superior performance to facilitate 256-QAM digital channel transmission capability
- Plug-in attenuators for RF gain control and front-panel RF testpoint for easy monitoring
- Downloadable firmware upgrades

## Specifications

---

### Optical

Optical Wavelength	1310nm ± 10nm
Optical Output Power	See CNR vs. Link Budget Tables

---

### RF

Bandwidth	
Operational Range	54 to 1002MHz
Analog Channel Range	54 to 550MHz
Digital Channel Range	550 to 1002MHz
Response Flatness, typ.	±0.5 dB
Input Return Loss	16 dB
Port-to-Port Isolation, typ.	60dB, 54 to 870MHz 50dB, 870 to 1002MHz
Port-to-Port Gain Variation, typ./max.	±0.5 dB/±1.0dB

---

### Powering

Power Consumption, max.	17.4W
-------------------------	-------

---

### Performance

Channel Plan	79 NTSC channels (up to 75 256-QAM channels)
Input RF Power	
Analog Channels (Notes 1 and 2)	15 dBmV/ch
Digital QAM Channels	9dBmV/ch
Composite Second Order (Notes 1 and 3)	-65dBc
Composite Triple Beat (Note 1)	-70dBc

---

### Mechanical

Optical Connector	SC/APC
RF Connector	F-type
RF Input Testpoint (Note 4)	-20 ± 1.0dB
Dimensions (W x H x D) (Note 5)	1.25 x 3.4 x 18.5 in. (3.2 x 8.7 x 47.0 cm)
Weight	2.75 lbs (1.24 kg)

---

### Environmental

Operational Temperature (Note 6)	32 to 122°F (0 to 50°C)
Storage Temperature	-40 to 158°F (-40 to 70°C)
Humidity, noncondensing, max.	85%

---

#### Notes:

1. Distortions are measured using only CW analog carriers per SCTE recommendation by standard RF test methods. Performance shown represents typical performance for ≥85% of production units tested over typical Corning SMF-28 fiber (or equivalent). For minimum CSO and CTB, subtract 2dB from typical.
2. OMI is 3.9% at 79 NTSC channel loading.
3. CSO performance for NTSC channels is for the in-band (high-side) beats.
4. Relative to main port with 0 dB pad and 0 dB EQ.
5. Includes handles and connectors.
6. Temperature measured at transmitter module's air inlet.

Specifications subject to change without notice

## CNR vs. Link Budget: CHP-GFXx-DF Series Dual-Input 1 GHz Transmitters

	Analog Loading	Digital Loading			
NTSC	79 channels, 54 to 550MHz	up to 75 channels 256-QAM, 550 to 1002MHz (6dB below analog)			
<b>Variable Output Transmitter</b>					
	CHP-GFXV-DF-04	CHP-GFXV-DF-06	CHP-GFXV-DF-08	CHP-GFXV-DF-10	CHP-GFXV-DF-12
Output Power Tunable Range (dBm)	2.0 to 4.0	4.0 to 6.0	6.0 to 8.0	8.0 to 10.0	10.0 to 12.0
Output Power (dBm)	4.0	6.0	8.0	10.0	12.0
Fiber Length (km)	7.0	13.0	15.0	15.0	20.0
Optical Loss Budget (dB)	CNR (dB) for part fiber/part passive link (typical)				
2	—	—	—	—	—
3	55.0	—	—	—	—
4	54.2	—	—	—	—
5	53.6	54.0	—	—	—
6	—	53.5	—	—	—
7	—	52.8	53.8	—	—
8	—	—	53.2	—	—
9	—	—	52.6	53.8	—
10	—	—	—	53.2	—
11	—	—	—	52.6	53.9
12	—	—	—	—	53.2
13	—	—	—	—	52.6
<b>Fixed Output Transmitter</b>					
	CHP-GFX-DF-13	CHP-GFX-DF-14	CHP-GFX-DF-15		
Optical Output Power (dBm)	13	14	15		
Fiber Length (km)	20	20	20		
Optical Loss Budget (dB)	CNR (dB) for part fiber/part passive link (typical)				
12	53.4	—	—		
13	52.8	53.4	—		
14	52.2	52.8	53.4		
15	51.5	52.2	52.8		
16	50.6	51.5	52.2		
17	—	50.6	51.5		
18	—	—	50.6		

Notes:

- Optical output power specified before transmitter's bulkhead.
- CNR variation is  $\pm 0.5$  dB within the tunable range if the receiver optical input power is adjusted to the same power level.
- The variable optical output power range can be extended 0.5 dB above and below the specified range, but distortions, as specified on the previous page, are not guaranteed in this extended range.
- CNR is measured using only CW analog carriers per SCTE test procedures. Performance shown is ambient. Subtract 0.5 dB for performance over full temperature range.
- OMI is automatically maintained within the tunable range except when operating in the custom manual mode.
- Specifications measured using typical receiver with 0.85 mA/mW, 7 pA/Hz<sup>0.5</sup> performance.
- All performance specified for 79 NTSC channels at 15 dBmV/channel and 450 MHz of digital loading at 6 dB below equivalent video channels.

Specifications subject to change without notice

# CHP Max5000 GFX(V)-DF 1 GHz Forward Path Transmitters

## Functional Block Diagram

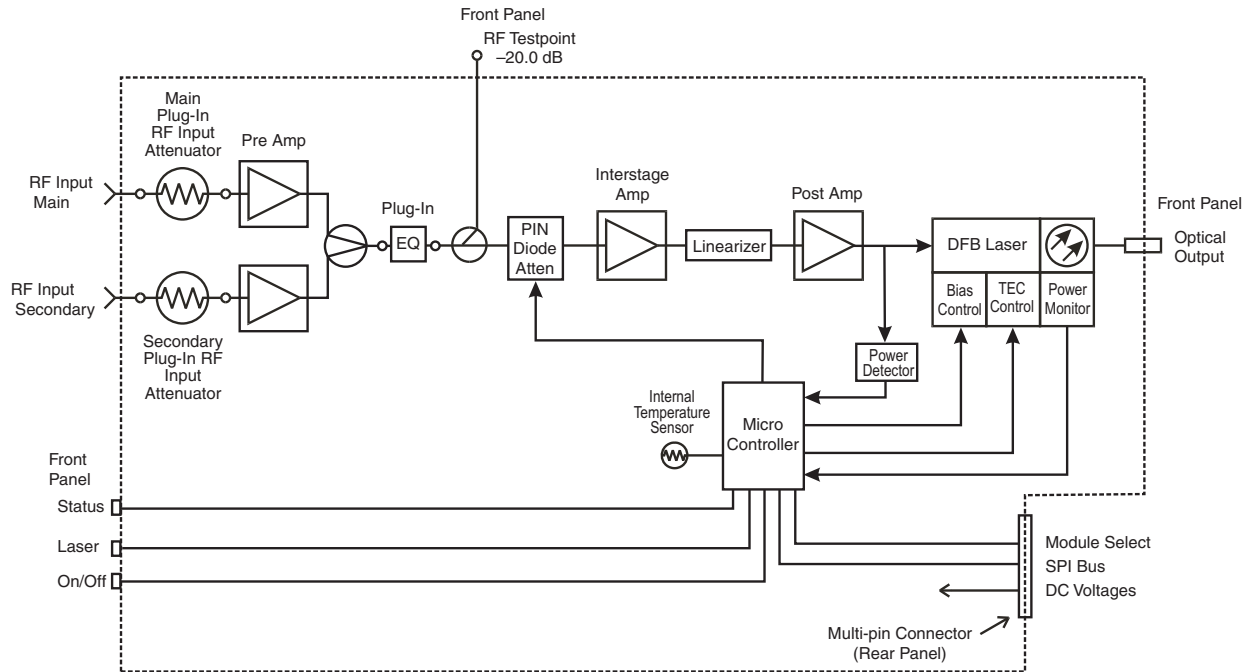

## Ordering Information

						<b>1</b>						<b>2</b>	<b>3</b>		<b>4</b>
C	H	P	-	G	F	X	x	-	D	F	-	x	x	-	S

1 Forward Transmitter Type	
blank	Fixed output transmitter series
V	Variable output transmitter series

4 Connector Type	
S	SC/APC

2-3 Optical Output Level		
04	Variable optical output power of 2 to 4 dBm in 0.25 dB steps	a
06	Variable optical output power of 4 to 6 dBm in 0.25 dB steps	a
08	Variable optical output power of 6 to 8 dBm in 0.25 dB steps	a
10	Variable optical output power of 8 to 10 dBm in 0.25 dB steps	a
12	Variable optical output power of 10 to 12 dBm in 0.25 dB steps	a
13	13.0 dBm fixed optical output power	b
14	14.0 dBm fixed optical output power	b
15	15.0 dBm fixed optical output power	b

a) Select "V" in #1 block, **Forward Transmitter Type**.

b) Leave the #1 block, **Forward Transmitter Type**, blank if ordering a fixed output transmitter.

Contact your ARRIS sales professional to discuss how our exciting new 1GHz products can add value to your network. See the CHP Max5000 Converged Headend Platform data sheet for additional ordering information.



The capabilities, system requirements and/or compatibility with third-party products described herein are subject to change without notice. ARRIS, the ARRIS logo, C3™, C4™, CableEdge™, Cadant™, C-COR™, CHP Max™, Cornerstone™, CXM™, D5™, Digicon™, Flex Max™, Keystone™, MONARCH™, n5™, nABLE™, NSM™, nVision™, PLEXIS™, Regal™, ServAssure™, TeleWire Supply™, Touchstone™, VoiceAssure™, and WorkAssure™ are all trademarks of ARRIS Group, Inc. Other trademarks and trade names may be used in this document to refer to either the entities claiming the marks and the names of their products. ARRIS disclaims proprietary interest in the marks and names of others. © Copyright 2008 ARRIS Group, Inc. All rights reserved. Reproduction in any manner whatsoever without the express written permission of ARRIS Group, Inc. is strictly forbidden. For more information, contact ARRIS.

CHPGFXVDF-D-0608

