



1 GHz 3-Input Forward Path RF Amplifier

CHP-GAMP3

C-COR® CHP Max5000



- 1 GHz technology
- One broadcast and two narrowcast RF inputs
- Broadcast and narrowcast gains are GUI adjustable
- Tunable equalization for broadcast input
- Reduced signal combining and cable wiring complexity
- Low profile footprint allows 200 amplifiers in a standard rack
- Universal local or remote management through Craft interface and SNMP with HMS

The ARRIS C-COR CHP Max5000 1 GHz 3-Input Forward Path RF Amplifier is a hot-swappable module that can be used as a key system component in a headend or hub environment to provide RF signal amplification and narrowcast layering. The innovative 3 RF inputs, 1 broadcast and 2 narrowcast, support layered services such as SDV, VOD, and HSD. This amplifier is designed to provide system operators a low cost way to overcome network losses, with minimal degradation to system performance, caused by combining and splitting networks that are typically found in HFC headends/hubs.

Up to 10 CHP Max5000 amplifiers can reside in the 2RU CHP Max5000 chassis, with one broadcast RF input, two narrowcast RF inputs, and one RF output connector access on the rear panel. A front panel RF testpoint provides a sample of the RF output, reduced by 20 dB.

Features

- 1 GHz single output with forward passband of 50 to 1002 MHz
- The maximum gain for the broadcast (BC) port is 20 dB, the narrowcast (NC) ports are 10 dB
- In-service tunable equalization of the broadcast input within the Craft GUI monitoring system reduces setup time and increases control
- 1 broadcast input and 2 narrowcast inputs supports layered narrowcast service implementation, such as SDV, VOD, and HSD
- Superior CNR and distortion performance
- BC port gain adjustable from 14 to 20 dB in 0.25 dB steps via Craft GUI or SNMP
- NC port gain is 13 dB less than BC gain with an adjustment range of ± 3 dB in 0.25 dB steps
- Superior reverse port-to-port isolation enables the combination of multiple narrowcast sources to reduce external signal combining and simplify cable wiring.
- Front-panel RF output testpoint for convenient monitoring
- Low profile footprint allows 10 amplifiers in a shelf

Specifications

RF	
Bandwidth, MHz	
Broadcast (BC) Port	50 to 1002
Narrowcast (NC) Ports, NC1 and NC2	400 to 1002
Response Flatness, typ., dB	
BC, NC1, NC2	±0.5
Response Tilt, max., dB	
BC Port at nominal tilt, NC1, NC2	±0.5
Return Loss for all four ports, min., dB	16
Gain, Fixed (Default), dB (Note 1)	
BC port	17
NC1 and NC2 ports	4
Gain, Adjustable Range, dB (Note 1)	
	Gain Range
BC port	14 to 20dB (0.25 dB steps)
NC1 port	BC Port Gain - 13 ± 3 (0.25 dB steps)
NC2 port	BC Port Gain - 13 ± 3 (0.25 dB steps)
Adjustable EQ Tilt (50 to 1002MHz, dB)	0 to 3 in 0.5 dB steps, BC port only
RF Output Testpoint, dB (Note 2)	-20 ± 0.5 @ 25°C; -20 ± 1.0 from 0 to 50°C
Port-to-port Isolation, min., dB	
BC to NC1, BC to NC2	50
NC1 to BC, NC2 to BC	42 at -10dB gain difference
NC1 to BC, NC2 to BC	48 at -16dB gain difference
NC1 to NC2, NC2 to NC1	50
Back Isolation, output port to any input port	60
Noise Figure for Broadcast Port, typ., dB	8 at 0dB tilt over the entire gain control range
Rated Input Level	15 dBmV/channel maximum for analog loading at BC port 25 dBmV/QAM channel maximum for digital loading at NC1 and NC2 ports
Performance Characteristic (Note 3)	
Composite Triple Beat (CTB), dBc	-85
Composite Second Order (CSO), dBc	-74
CIN, dBc	-70
XMOD, dBc	-79
Powering	
Power Consumption, max., W	12.5
Mechanical	
RF Connectors	F-type
Dimensions (W x H x D) (Note 4), in. (cm)	1.25 x 3.4 x 18.5 (3.2 x 8.7 x 47.0)
Weight, lbs (kg)	2.75 (1.24)
Environmental	
Operating Temperature (Note 5), °C (°F)	0 to 50 (32 to 122)
Storage Temperature, °C (°F)	-40 to 70 (-40 to 158)
Operating Humidity, nonconducting, max.	85%
Storage Humidity, noncondensing, max.	95%

Notes:

1. Default gain is 17 dB for BC port and is 4 dB for NC1 and NC2 ports in Preset Manual mode. Using the GUI in Custom Manual mode, the BC port gain adjustment range is 14 to 20dB in 0.25 dB steps and the NC1 and NC2 port gain adjustment range is -16 to -10dB in 0.25 dB steps relative to the BC port gain. Adjusting the BC port gain also affects the gain of the narrowcast ports (NC1 and NC2).
2. Relative to output port.
3. Specifications obtained using 79 NTSC CW channels (50 to 550MHz) with an input of 15 dBmV/channel applied to the input of the BC port, and full digital loading (550 to 1002MHz) with 25 dBmV/channel maximum applied to one of the NC ports. At the output of the CHP-GAMP3, the level per digital channel is 6dB lower than the analog channels. The gain for the BC port is 20dB and the NC gain difference is -16dB (NC gain is 4dB). The tilt is 0dB.
4. Includes handles and connectors.
5. Temperature measured at amplifier module's air inlet.

Specifications subject to change without notice

HeaderProdName Product Description

Functional Block Diagram

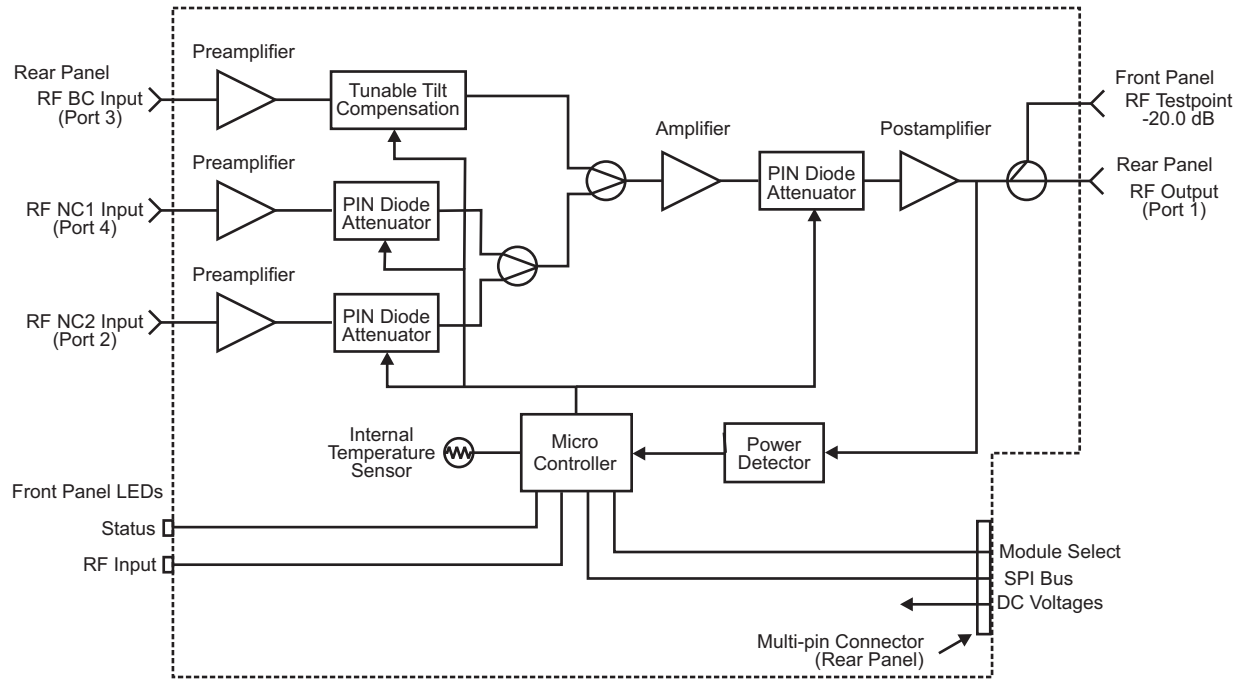

Ordering Information

				1	2	3	4	5
C	H	P	-	G	A	M	P	3

1-5	Type of Module
GAMP3	1GHz 3-input forward path RF amplifier

Contact your C-COR sales professional to discuss how our exciting new 1 GHz products can add value to your network.



The capabilities, system requirements and/or compatibility with third-party products described herein are subject to change without notice. ARRIS, the ARRIS logo, C3™, C4™, CableEdge®, Cadant®, C-COR®, CHP Max®, Cornerstone®, CXM™, D5™, Digicon®, Flex Max®, Keystone™, MONARCH®, n5™, nABLE™, NSM®, nVision®, PLEXIS®, Regal®, ServAssure™, TeleWire Supply®, Touchstone®, VoiceAssure™, and WorkAssure™ are all trademarks of ARRIS Group, Inc. Other trademarks and trade names may be used in this document to refer to either the entities claiming the marks and the names of their products. ARRIS disclaims proprietary interest in the marks and names of others. © Copyright 2008 ARRIS Group, Inc. All rights reserved. Reproduction in any manner whatsoever without the express written permission of ARRIS Group, Inc. is strictly forbidden. For more information, contact ARRIS.

CHPGAMP-D-0508

